



**Food transports**



*The optimum solution.*

# Food transports

## About us

Food transports by silo truck and container is one of our continuous increasing product sectors.

### Food transports

The high requirements of the food industry are implemented faithfully by SCHMIDT and the transport technology is improved constantly by internal innovations.

Customers looking for logistics solutions for dry bulk goods such as grain, corn, rice, sugar, malt etc. have a competent partner with SCHMIDT.



30° Steel boxcontainers with inliner

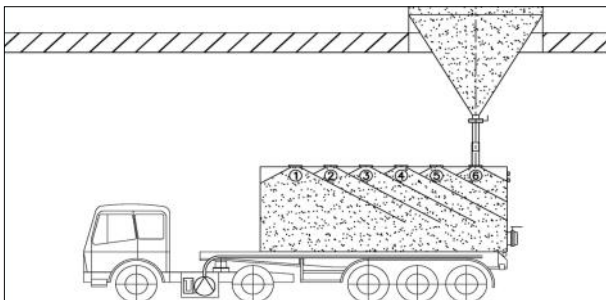

Loading containers (all types)



30° Alu boxcontainers/High Cube

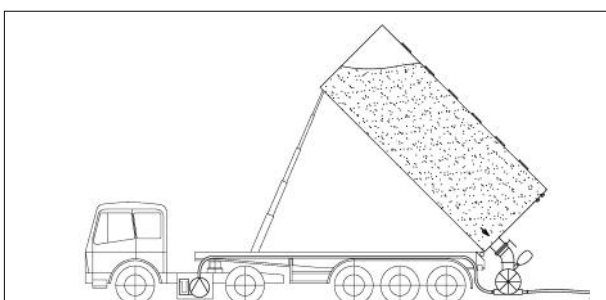

Unloading steel- and alu boxcontainers



30° and 40° pressurised containers

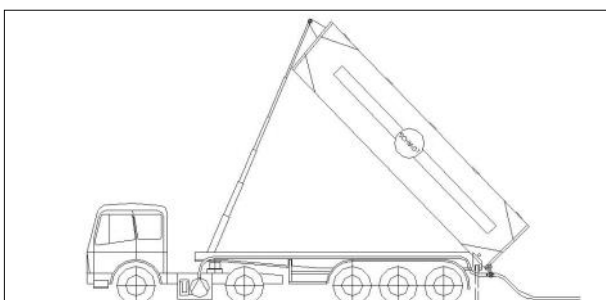

Unloading pressurised containers



Silo trucks

# Food transports

## Equipment overview

Containers are the optimal solution for longer transport routes and temporary storage. Silo trucks help with the regional distribution and transport of non-containerable products.

	30' Steel-Box-Container	30' Alubox-Container	Pressurized Container		Silo truck
			30'	40'	
<b>Volume:</b>	56 m <sup>3</sup>	56 m <sup>3</sup> / 59 m <sup>3</sup>	42 m <sup>3</sup> - 50 m <sup>3</sup>	56 m <sup>3</sup>	59 m <sup>3</sup>
<b>Tare weight:</b>	2.8 - 2.9 t	1.8 - 2.1 t / 2.3 t	2.2 - 3.2 t	2.5 - 3.0 t	6.0 t
<b>Max. capacity</b>	27 - 28 t	28 - 29 t	27 t	27 t	25 t
<b>Discharge:</b>	Rotary valve or free fall		Compressed air		
<b>Discharge time:</b>	Approx. 20-25 t / hour, depending on product		Approx. 25 t / hour		
<b>Exclusion of contamination:</b>	Disposable inliner made of food-conform polyethylene film acc. Directive 2002/72/EC	Cleaning at certified cleaning stations or dedicated traffic			
<b>Suitable for:</b>	<b>All granulated food stuff, e.g.:</b> <ul style="list-style-type: none"> <li>• Sugar</li> <li>• Rice</li> <li>• Grain</li> <li>• Corn</li> <li>• Malt</li> <li>• Salt</li> <li>• Coffee beans</li> <li>• Pulse</li> </ul>		<b>All powdered food stuff, e.g.:</b> <ul style="list-style-type: none"> <li>• Starch</li> <li>• Milk powder</li> <li>• Flour</li> <li>• Semolina</li> <li>• Rice flour</li> </ul>		
<b>Features:</b>	<ul style="list-style-type: none"> <li>• Inliner serving as closed-off transport system</li> <li>• Rotary valve ensures gentle discharge of product</li> <li>• Easy sampling by SCHMIDT safety liner</li> </ul>	<ul style="list-style-type: none"> <li>• Low tare weight allows an optimum payload and saving of transport costs</li> <li>• Rotary valve ensures gentle discharge of product</li> <li>• Specially suited for dedicated traffics</li> </ul>	<ul style="list-style-type: none"> <li>• Optimum solution for powdered food stuff</li> <li>• Discharge by compressed air corresponding to bulk trucks</li> <li>• Specially suited for dedicated traffics</li> </ul>		
<b>All container-types have in common:</b>	<ul style="list-style-type: none"> <li>• Loading corresponding to bulk trucks</li> <li>• 4-6 manholes in order to distribute product evenly</li> <li>• Optimum capacity of 27 – 29 t per transport</li> <li>• Option for warehousing and quick delivery on demand</li> <li>• Cost-effective alternative for long distances</li> <li>• Quality at the highest level</li> <li>• Exclusive SCHMIDT discharge equipment</li> <li>• Clear separation from other product groups</li> <li>• Environmentally friendly handling of transports</li> </ul>				

## SCHMIDT Container terminals

Positioned strategically worldwide, SCHMIDT has an extensive infrastructure available to ensure safe processing of import and export business by sea containers. By making use of their successful inliner technology, the highest level of safety and quality is ensured for sensitive food stuffs.

### Food imports and exports

When developing their special inliners, SCHMIDT provides crucial impulses to manufacturers to constantly optimize inliner functions according to specific product requirements. Based on state-of-the-art equipment and a diligent execution of transport, handling and warehousing your food transports are in good hands with us!

### Features of food transports

- European infrastructure providing container pools available on short notice
- 12 container depots for a reliable handling of oversea flows from / into Europe
- Total logistics solutions for food imports/exports
- Extensive intermodal network for the use of rail- and waterways
- Handling within ports incl. customs clearance
- Designing train concepts for large volumes and regular traffic flows
- Intermediate warehousing upon request
- Inliners for the singular use in containers
- Cleaning at certified cleaning stations by state-of-the-art spinner head rinsing technology
- SCHMIDT's transport and discharge technology is improved by continuous innovations
- Minimizing costs and time effort through established technologies

### Discharging sea containers with bulk goods

- Discharge via tilting chassis and rotary valve
- Discharge via free fall or transloading via tilting platform into bulk containers

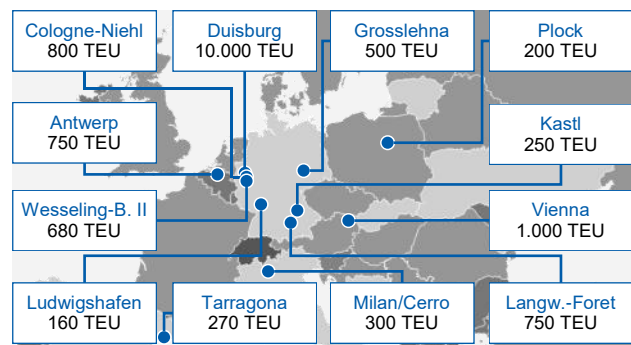

**Karl SCHMIDT Spedition GmbH & Co. KG**  
 Rötelstraße 1 • 74076 Heilbronn / Germany  
 Tel.: +49 7131 / 947-0 • Fax: +49 7131 / 947-155  
 E-Mail: [info@schmidt-heilbronn.de](mailto:info@schmidt-heilbronn.de)

[www.schmidt-heilbronn.de](http://www.schmidt-heilbronn.de)

